

General Specifications

Outdoor models

PVI-3.0-OUTD / PVI-3.0-OUTD-S

PVI-3.6-OUTD / PVI-3.6-OUTD-S

PVI-4.2-OUTD / PVI-4.2-OUTD-S

AURORA® BENEFITS

- Dual input section to process two strings with independent MPPT
- High speed MPPT for real time power tracking and improved energy harvesting
- Transformerless operation for highest efficiency: up to 96,8% (Euro 96%)
- Reverse polarity protection minimizes chance of damage due to mis-wiring
- True Sine Wave Output
- Anti-islanding Protection
- LCD Display on the front to monitor the main parameters
- Integrated DC switch in compliance with VDE 0100-712 (Germany) and CEI 64-8 V4 (Italy)
- Standard DC Multi-Contact terminals (model MC4), includes an integrated DC switch (PVI-X.X-OUTD-S)



STANDARDS AND CODES

Aurora inverters comply with standards set for grid-tied operation, safety and electromagnetic compatibility including: VDE0126, CEI 11-20 IV ed, DK5940, IEC 61683, IEC 61727, EN50081, EN50082, EN61000, CE certification, El Real Decreto RD1663/2000 de España.

Block Diagram and typical efficiency

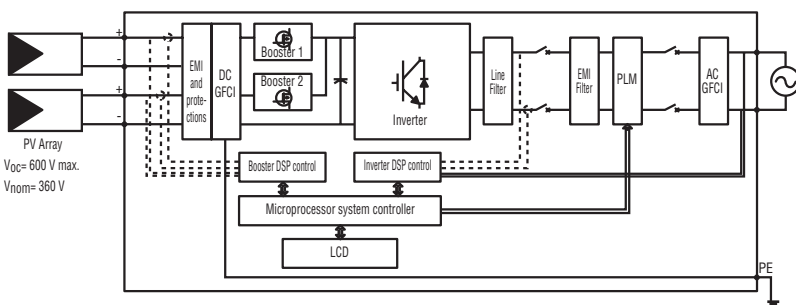
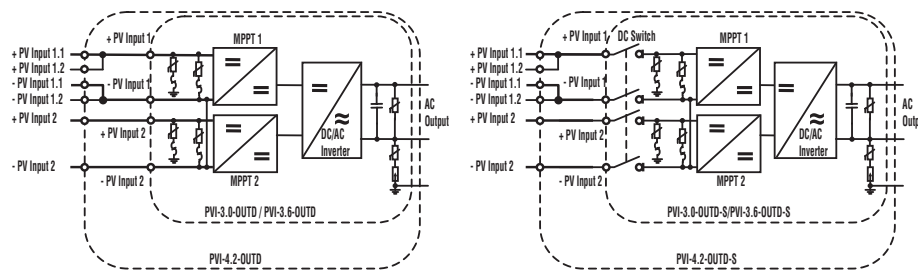

PVI-4.2-OUTD Efficiency

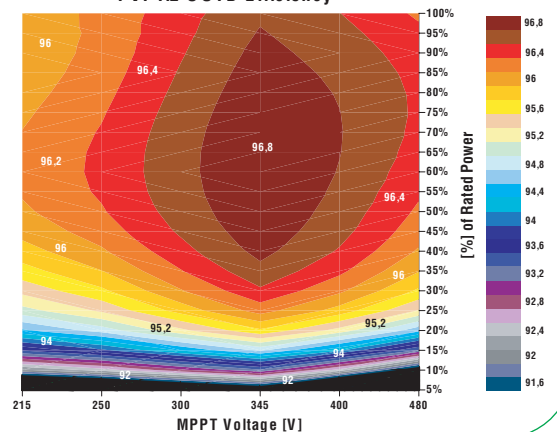

CHARACTERISTICS	PVI-3.0-OUTD	PVI-3.6-OUTD	PVI-4.2-OUTD
INPUT PARAMETERS			
Nominal DC Power [kW]	3,12	3,75	4,38
Max. Recommended DC Power [kW]	3,5	4,15	4,82
Operating Input Voltage Range [V]	0,7xVstart - 580 (360 nominal)		
Full Power MPPT input voltage range (symmetrical load) [V]	156-530	120-530	140-530
Full asymmetrical load input voltage range [V]	200-530 (@ 2kW) / 112-530 (@ 1,12kW)	190-530 (@ 3kW) / 90-530 (@ 0,75kW)	190-530 (@ 3kW) / 90-530 (@ 1,38kW)
Absolute Max. Input Voltage [V]	600		
Activation voltage "Vstart" [V]	200 nominal (adjustable within the range 120Vdc-350Vdc, independently/each input)		
No of independent MPPT trackers	2		
Max. Input Power, each MPPT [kW]	2	3	3
No. of DC Inputs	2 (1 each MPPT)		3 (2 for MPPT1, 1 for MPPT2)
Max. DC Current, each MPPT [A]	10 (12,5 short circuit)	16 (20 short circuit)	
DC Connection	4 (2 positive, 2 negative)		6 (3 positive, 3 negative)
	MultiContact Ø 4mm (male - positive input + female - negative input)		
	Mating cable connector included		
	Conductor cross section: 4-6mmq/AWG12-10 - Cable Ø w/insulator: 3-6mm		
INPUT PROTECTION			
Reverse polarity protection	Yes		
Fuse rating, each input (-FS suffix versions only)	NA	NA	NA
Thermally Protected DC side varistor	4 (2 for each MPPT)		
PV array Insulation Control	according to VDE0126-1-1		
DC Switch (-S/-FS suffix versions only)	Integrated (Max. Voltage Rating : 600Vdc / Max Current Rating: 25A)		
OUTPUT PARAMETERS			
Nominal AC Power [up to 50°C, kW]	3	3,6	4,2
Max. AC Power [kW]	3,3	3,96	4,6
AC Grid Connection	single phase (Live, Neutral, PE)		
Nominal AC Voltage Range [V]	200-245 (230 nominal)		
Maximum AC Voltage Range [V]	180-264 (may vary to comply with regulations in each country)		
Nominal AC Frequency [Hz]	50		
Max. AC Line Current [A]	14,5 (16 short circuit)	17,2 (19 short circuit)	20 (22 short circuit)
AC Connection	Screw terminal block		
	Conductor cross section: Solid 0,5-16mmq / Stranded: 0,5-10mmq / AWG20-6		
	Cable Gland: M32 - Cable Ø: 13-21mm		
Line Power Factor	1		
AC Current Distortion [THD%]	<3,5% at rated power with sine wave voltage		
OUTPUT PROTECTION			
AC side varistors	2 (Live - Neutral / Live - PE)		
Ground fault protection (AC + DC leakage current)	according to VDE0126-1-1		
CONVERSION EFFICIENCY			
Max. Efficiency	96,80%		
Euro Efficiency	96%		
ENVIRONMENTAL PARAMETERS			
Cooling	Natural cooling		
Ambient Temp. Range [°C]	-25 / + 60 (output power derating above 50°C)		
Operating Altitude [m]	2000		
Acoustical Noise [dBA]	< 50 @ 1mt		
Environmental IP Rating	IP65		
Relative Humidity	0-100% condensing		
MECHANICAL			
Dimensions [H x W x D]	547 x 325 x 208		
Weight [kg]	17		
OTHER			
Stand-By Consumption [W]	8		
Feed In Power Threshold [W]	10		
Night Time consumption [W]	0,3		
Isolation	Transformer-less		
Display	YES (Alphanumeric 2 lines)		
Communication	RS485 (Screw terminal block - Conductor cross section: 0,08-1,5mmq/AWG28-16)		
	USB connection "Aurora Easy-Control" system for remote control (Optional)		
AVAILABLE PRODUCT VARIANTS			
Standard - no options	PVI-3.0-OUTD	PVI-3.6-OUTD	PVI-4.2-OUTD
With DC switch	PVI-3.0-OUTD-S	PVI-3.6-OUTD-S	PVI-4.2-OUTD-S
With DC switch and blocking diode/each input	NA	NA	NA

MODEL SUMMARY

MODEL NUMBER	POWER
PVI-3.0-OUTD/-S	3000W
PVI-3.6-OUTD/-S	3600W
PVI-4.2-OUTD/-S	4200W